

产品及应用 PRODUCTS APPLICATIONS

- ▲ 端子台连接，接线方便，安全可靠
- ▲ 优异的共模和差模抑制能力，极佳的低频段衰减特性可提高系统功率因数，缓解三相不平衡
- ▲ 适用于工业电源、逆变电源、机床设备、变频设备等



- ▲ Terminal block connection, easy wiring, safe and reliable
- ▲ Excellent common mode and differential mode suppression capabilities, excellent low frequency band attenuation characteristics can improve the system power factor, and alleviate three-phase
- ▲ It is suitable for industrial power supplies, inverter power supplies, machine tools, frequency conversion equipment, etc

技术参数 SPECIFICATION

最高工作电压 Maximum operating voltage (VAC)	工作频率 Operating frequency Hz	试验电压 Hipot test voltage P-N(VDC) P-E(VDC)		工作温度 Operating temperature Hz	绝缘电阻 Minimum insulation resistance
440	50/60	2150	2700	25/85/21	>200M@500VDC

产品型号 FILTER	额定电流 Current rating @40°C	泄露电流 Leakage current	变频器功率 Inverter power (KW)	外型尺寸 Housing	重量 Weight (g)
YB920TR-5	5A	<5.0mA	0.75/1.5	N2T	1100
YB920TR-8	8A	<5.0mA	2.2/3.7	N2T	1100
YB920TR-10	10A	<5.0mA	4	N2T	1100
YB920TR-16	16A	<5.0mA	5.5/7.5	N5T	1500
YB920TR-20	20A	<5.0mA	7.5/8.0	N5T	1500
YB920TR-30	30A	<7.5mA	11/15	N5T	1500
YB920TR-45	45A	<15mA	18.5/22	N10T	2500
YB920TR-60	60A	<15mA	25/28	N10T	2500
YB920TR-75	75A	<20mA	30/37	N12T	7000
YB920TR-100	100A	<25mA	45	N12T	7000
YB920TR-120	120A	<25mA	55	N12T	7000
YB920TR-150	150A	<30mA	75	N15T	10000

电路原理图 CIRCUIT DIAGRAM

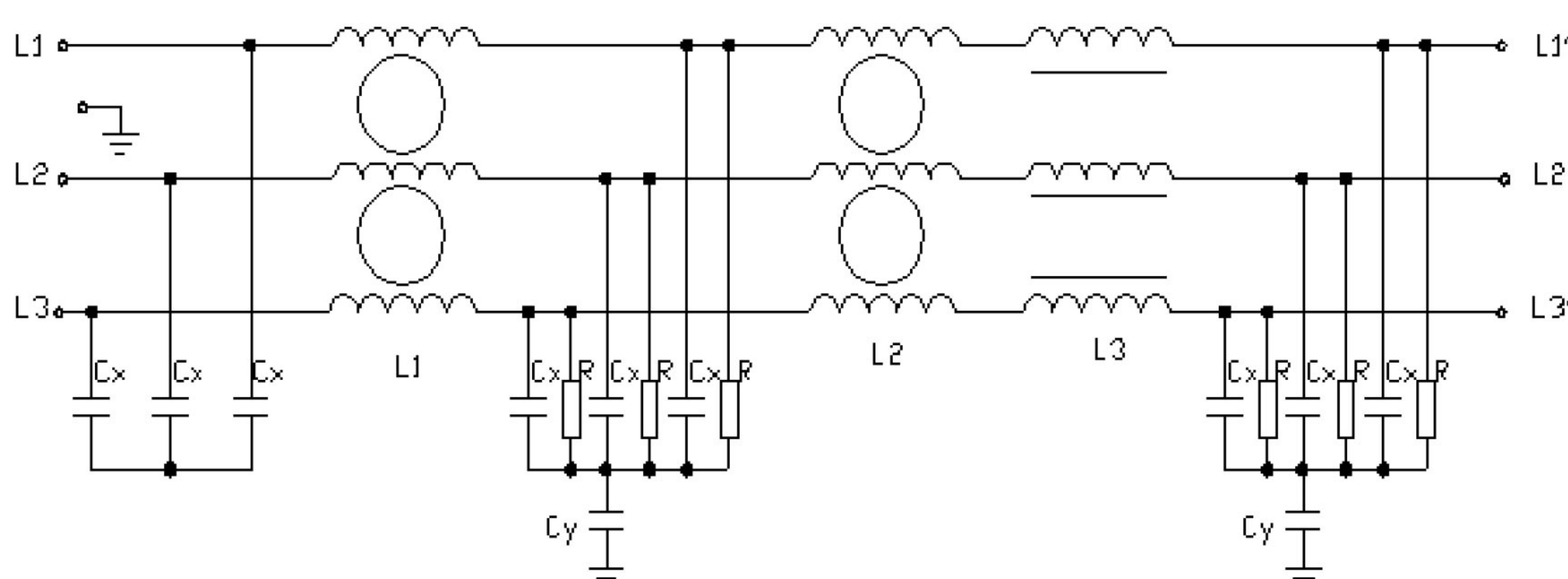

外型尺寸 HOUSING AND DIMENSIONS: (MM)

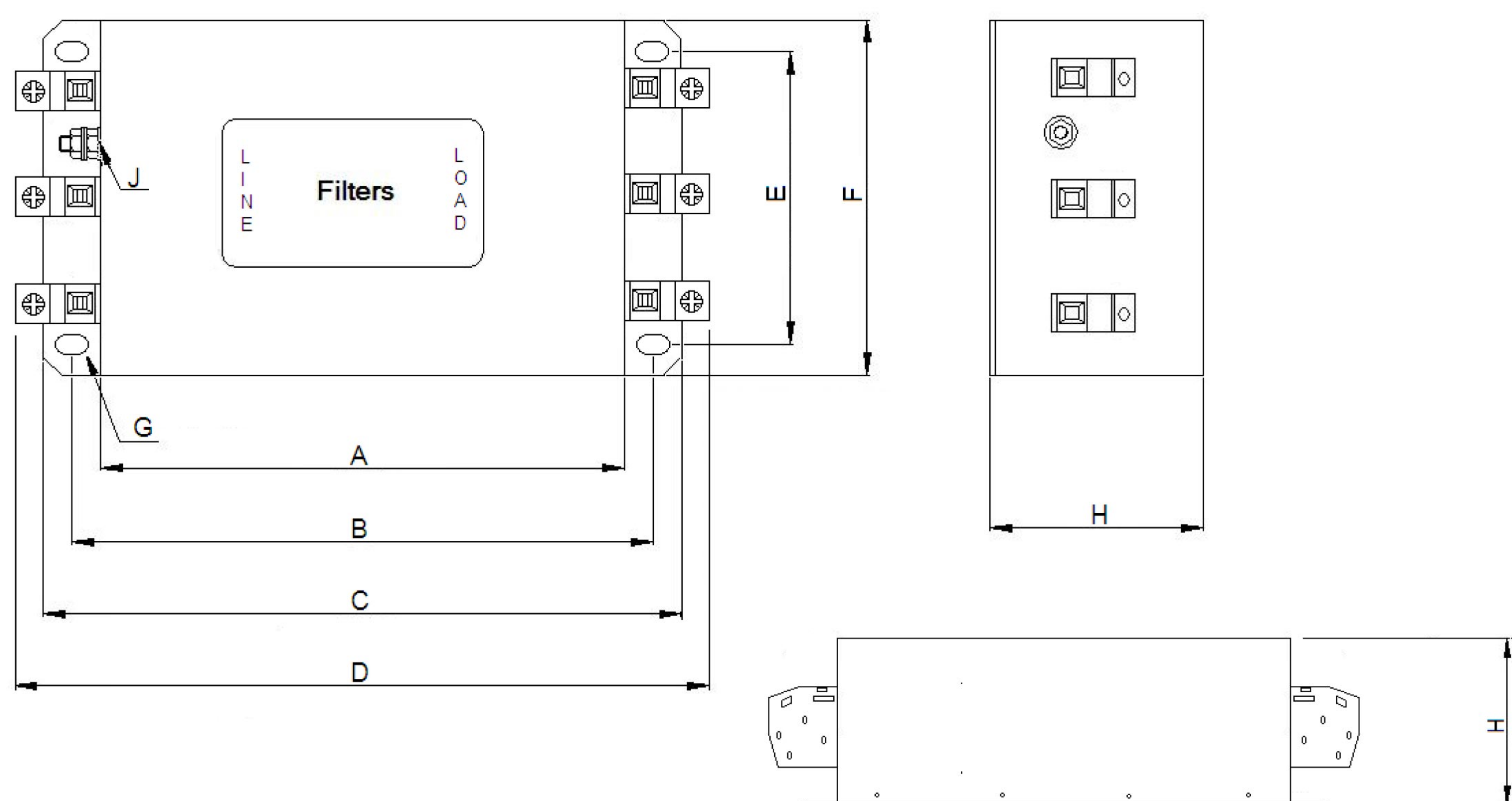

	A	B	C	D	E	F	G	H	J
N2T	110	125±1.0	140	156±1.0	70±0.5	93	5.3*7	56	M4
N5T	150	168±1.5	186	199±1.5	85±0.5	108	6.4*9	60	M4
N10T	200	220±1.5	240	260±1.5	100±1.0	125	6.4*9	80	M6
N12T	260	286±2.5	314	335±2.5	140±1.0	175	8.8*14	107	M6
N15T	300	326±3.0	354	380±3.0	150±1.5	185	8.8*14	115	M6

端子台安装方式	-10	-16	-25	-50
单芯线	16mm ²	25mm ²	35mm ²	50mm ²
多芯线	10mm ²	16mm ²	25mm ²	50mm ²
扭力	1.7 N·m	2.8 N·m	3.8 N·m	5.9 N·m
剥线长度	10mm	16mm	19mm	24mm